

LCD Module Specification

Model No.: LG12864H-FFDWH6V
LG12864H-LMDWH6V

Table of Contents

| | |
|---|----|
| 1. BASIC SPECIFICATIONS | 2 |
| 2. ABSOLUTE MAXIMUM RATINGS | 4 |
| 3. ELECTRICAL CHARACTERISTICS | 4 |
| 4. DISPLAY CONTROL COMMANDS | 8 |
| 5. CONNECTION WITH 8051 FAMILY MPU | 9 |
| 6. INITIALIZATION AND POWER OFF | 10 |
| 7. ELECTRO-OPTICAL CHARACTERISTICS | 11 |
| 8. DIMENSIONAL OUTLINE | 12 |
| 9. LCD MODULE NUMBERING SYSTEM | 13 |
| 10. PRECAUTIONS FOR USE OF LCD MODULE | 14 |

RECORD OF REVISION

| Rev. | Date | Page | Item | Description |
|------|------------|------|------|--|
| 0.1 | 2010/07/28 | - | - | New release |
| 0.2 | 2010/10/26 | 2 | 1.1 | Remove BMDWH6V and SFDWH6V LCD type |
| 0.3 | 2012/11/28 | 9 | 5 | Add description of anti-interference capacitors. |

1. BASIC SPECIFICATIONS

1.1 Features

| Item | | Specifications | Unit |
|---------------------------|---------|---|---------|
| Display Format | | 128 x 64 | dot |
| LCD Type | FFDWH6V | FSTN - Positive - Transflective Black characters on white background | - |
| | LMDWH6V | FSTN - Blue - Negative - Transmissive Pure white characters on blue background | - |
| Driving Method | | 1/65 Duty, 1/9 Bias | - |
| Viewing Direction | | 6:00 | O'clock |
| Backlight & Color | | LED, white color | - |
| Outline Dimension (WxHxT) | | 42.9 x 37.9 x 8.5 (FPC length not included) | mm |
| Viewing Area (WxH) | | 39.0 x 28.0 | mm |
| Active Area (WxH) | | 36.07 x 23.01 | mm |
| Dot Pitch (WxH) | | 0.282 x 0.36 | mm |
| Dot Size (WxH) | | 0.252 x 0.33 | mm |
| Weight | | 14 | g |
| Controller | | ST7565P (COG) | - |
| Interface | | 8-bit parallel (6800 series MPU) or serial | - |
| Power Supply (VDD) | | 3.0 to 3.3 | V |

1.2 Block Diagram

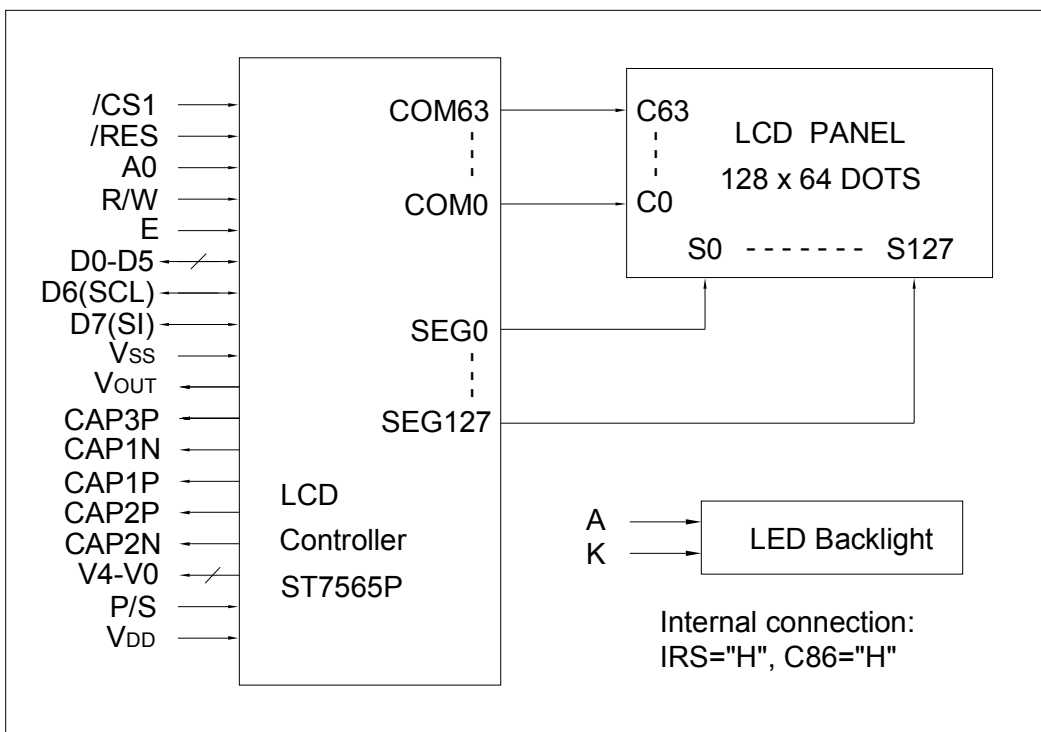

1.3 Terminal Functions

| Pin No. | Symbol | Level | Function |
|---------|----------|------------|--|
| 1 | VDD | 3V to 3.3V | Power supply for logic and DC/DC converter |
| 2 | P/S | H/L | Parallel/Serial data input selection. P/S="H": Parallel data input P/S="L": Serial data input When P/S="L", D0 to D5 should be fixed to "H". E, R/W are fixed to either "H" or "L". Serial mode does not support read operation. |
| 3 | VSS | 0V | Ground |
| 4 | V0 | - | Power supply for LCD drive. Connect a capacitor to VSS |
| 5 | V1 | - | Power supply for LCD drive. Connect a capacitor to VSS |
| 6 | V2 | - | Power supply for LCD drive. Connect a capacitor to VSS |
| 7 | V3 | - | Power supply for LCD drive. Connect a capacitor to VSS |
| 8 | V4 | - | Power supply for LCD drive. Connect a capacitor to VSS |
| 9 | CAP2N | - | DC/DC voltage converter capacitor 2 negative connection |
| 10 | CAP2P | - | DC/DC voltage converter capacitor 2 positive connection |
| 11 | CAP1P | - | DC/DC voltage converter capacitor 1 positive connection |
| 12 | CAP1N | - | DC/DC voltage converter capacitor 1 negative connection |
| 13 | CAP3P | - | DC/DC voltage converter capacitor 3 positive connection |
| 14 | VOUT | - | DC/DC voltage converter output. Connect a capacitor to VSS. |
| 15 | VSS | 0V | Ground |
| 16 | D7 (SI) | H/L | <p>When P/S="H" (Parallel interface mode): D0 to D7 are 8-bit bi-directional data bus.</p> <p>When P/S="L" (Serial interface mode): D7 is serial data input (SI). D6 is serial clock input (SCL). D0 to D5 should be connected to VDD.</p> |
| 17 | D6 (SCL) | H/L | |
| 18 | D5 | H/L | |
| 19 | D4 | H/L | |
| 20 | D3 | H/L | |
| 21 | D2 | H/L | |
| 22 | D1 | H/L | |
| 23 | D0 | H/L | |
| 24 | E | H, H->L | Enable signal for 6800 series MPU. Read data when E is "H", write data at falling edge of E. |
| 25 | R/W | H/L | R/W signal for 6800 series MPU. R/W="H": Read; R/W="L": Write |
| 26 | A0 | H/L | Data or instruction selection. A0="H": D0 to D7 are display data. A0="L": D0 to D7 are Instruction code. |
| 27 | /RES | L | Reset signal. Active "L". |
| 28 | /CS1 | L | Chip selection signal. Active "L". |

Note: IRS and C86 terminals are connected to VDD on ITO glass. ST7565P is set to use internal resistors for V0 voltage adjustment and 6800 series MPU interface.

2. ABSOLUTE MAXIMUM RATINGS

| Item | Symbol | Condition | Min. | Max. | Unit |
|---------------------------------------|----------|------------|------|---------|------|
| Supply Voltage (Logic and Booster) | VDD | 4x booster | -0.3 | 3.6 | V |
| Supply Voltage (LCD) | V0, VOUT | | -0.3 | 14.5 | V |
| Input Voltage | VI | | -0.3 | VDD+0.3 | V |
| Operating Temperature | Topr | | -20 | 70 | °C |
| Storage Temperature | Tstg | | -30 | 80 | °C |

3. ELECTRICAL CHARACTERISTICS

3.1 DC Characteristics (Ta=25°C)

| Item | Symbol | Condition | Min. | Typ. | Max. | Unit |
|---------------------------------------|--------|------------------------|--------|------|--------|------|
| Supply Voltage (Logic and Booster) | VDD | 4x booster | 3.0 | - | 3.3 | V |
| Supply Voltage (LCD Drive) | V0 | | - | 9.9 | - | V |
| Input High Voltage | VIH | | 0.8VDD | - | VDD | V |
| Input Low Voltage | VIL | | 0 | - | 0.2VDD | V |
| Output High Voltage | VOH | IOH=-0.1mA | 0.8VDD | - | VDD | V |
| Output Low Voltage | VOL | IOL=0.1mA | 0 | - | 0.2VDD | V |
| Supply Current | IDD | VDD=3.3V 4x booster | - | 0.4 | 0.8 | mA |

3.2 System Bus Read/Write Characteristics (6800 Series MPU, VDD=3.3V, Ta=25°C)

| Parameters | Signal | Symbol | Min. | Max. | Condition | Unit |
|----------------------|--------------|-------------------|------|------|-----------|------|
| Address Hold Time | A0, R/W | t _{AH6} | 0 | - | | ns |
| Address Setup Time | | t _{AW6} | 0 | - | | |
| System Cycle Time | E | t _{CYC6} | 240 | - | | |
| Enable L Pulse Width | E (Write) | t _{EWLW} | 80 | - | | |
| Enable H Pulse Width | | t _{EWHW} | 80 | - | | |
| Enable L Pulse Width | E (Read) | t _{EWLR} | 80 | - | | |
| Enable H Pulse Width | | t _{EWHR} | 140 | - | | |
| Data Setup Time | D0 to D7 | t _{DS6} | 40 | - | | |
| Data Hold time | | t _{DH6} | 0 | - | | |
| Read Access Time | | t _{ACC6} | - | 70 | CL=100pF | |
| Output Disable Time | | t _{OH6} | 5 | 50 | CL=100pF | |

*1 The input signal rise and fall time (tr, tf) is specified at 15 ns or less.

*2 All timing is specified using 20% and 80% of VDD as the reference.

*3 t_{EWHW} and t_{EWHR} are specified as the overlap period when /CS1 is "L" and E is "H".

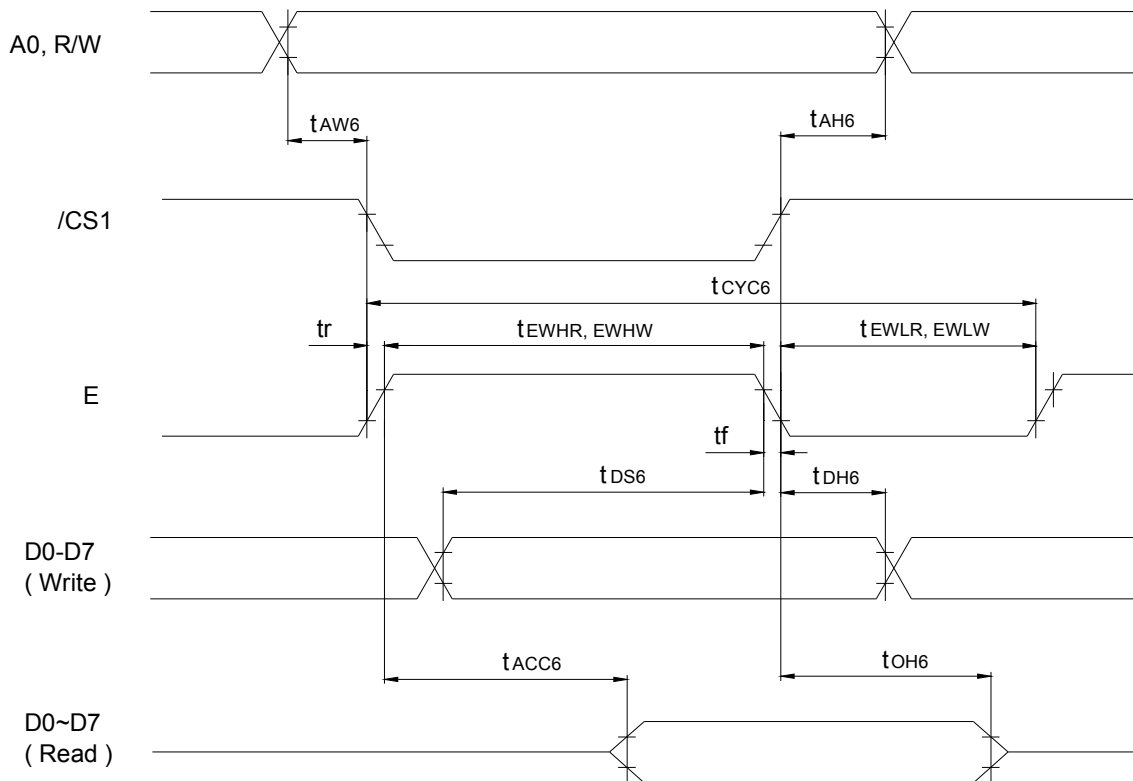

Bus Read/Write Timing (6800 Series MPU)

3.3 Serial Interface (VDD=3.3V, Ta=25°C)

| Parameters | Signal | Symbol | Min. | Max. | Condition | Unit |
|---------------------|--------|--------|------|------|-----------|------|
| Serial Clock Period | SCL | tSCYC | 50 | - | | ns |
| SCL H Pulse Width | | tSHW | 25 | - | | |
| SCL L Pulse Width | | tSLW | 25 | - | | |
| Address Setup Time | A0 | tSAS | 20 | - | | |
| Address Hold Time | | tSAH | 10 | - | | |
| Data Setup Time | SI | tSDS | 20 | - | | |
| Data Hold Time | | tSDH | 10 | - | | |
| CS-SCL Time | /CS1 | tCSS | 20 | - | | |
| CS-SCL Time | | tCSH | 40 | - | | |

*1 The input signal rise and fall time (t_r , t_f) are specified at 15 ns or less.

*2 All timing is specified using 20% and 80% of VDD as the standard.

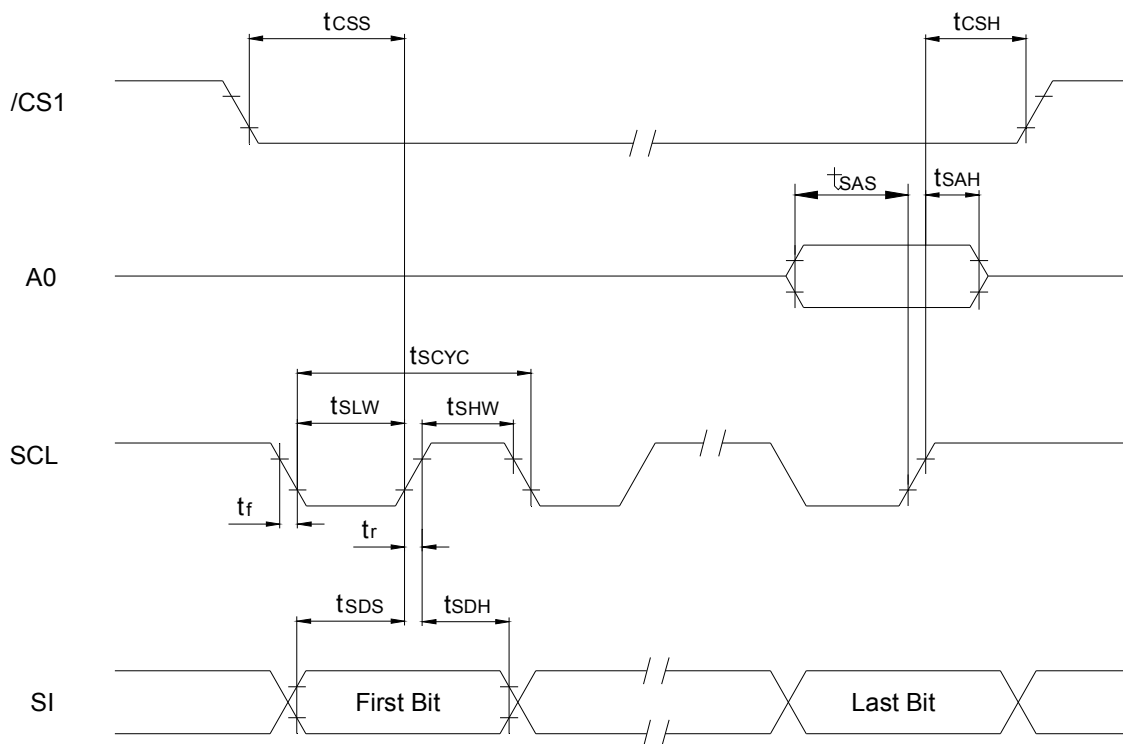

Serial Interface Timing

3.4 LED Backlight Characteristics (Ta=25°C)

| Item | Symbol | Condition | Min. | Typ. | Max. | Unit |
|-----------------|--------|-----------|------|------|------|------|
| Forward Voltage | Vf | | 2.8 | 2.9 | 3.1 | V |
| Forward Current | If | Vf=2.9V | - | 20 | - | mA |
| Color | White | | | | | |

* RLED is the current limiting resistor for LED backlight. $R_{LED} = (V_{LED} - 2.9V) / 20mA$

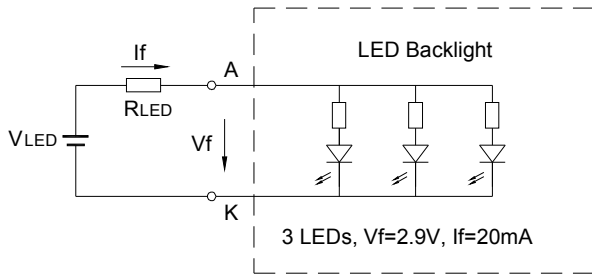

Recommended vaule for RLED

| VLED | RLED |
|------|------------------|
| 5.0V | 110 Ω ±1%, 1/4W |
| 3.3V | 20 Ω ±1%, 1/10W |
| 3.0V | 5.1 Ω ±1%, 1/10W |

3.5 Power Supply for Logic and LCD Driving (VDD=3.0V to 3.3V, 4x booster)

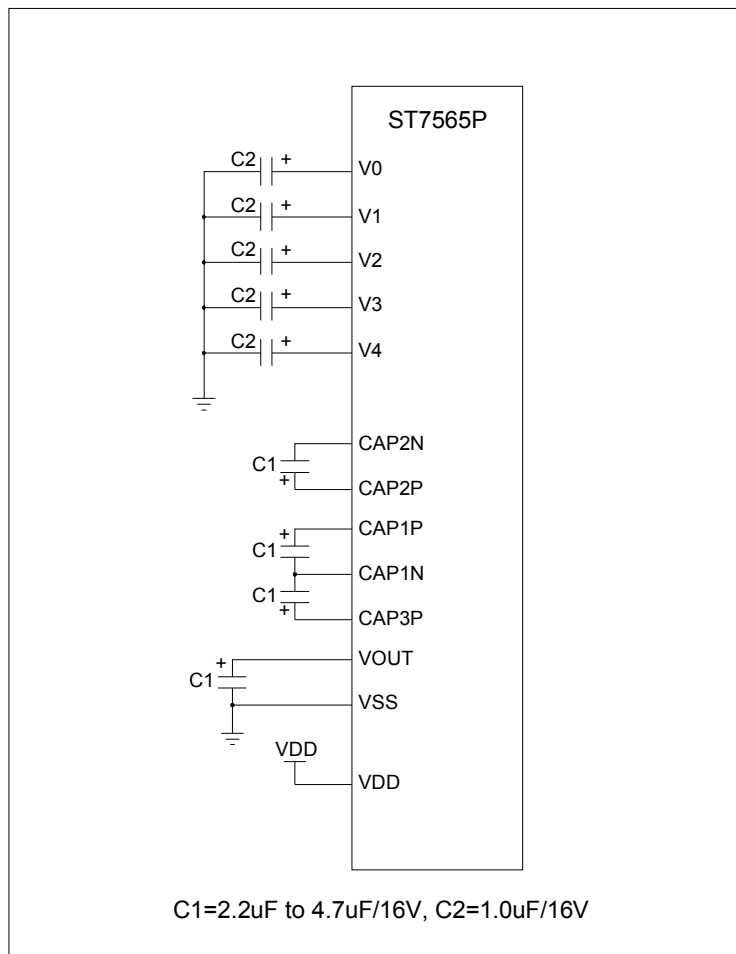

4. DISPLAY CONTROL COMMANDS

| Command | Command Code | | | | | | | | | | | Function |
|---|--------------|--------|--------|--------|--------|--------|--------|--------|--------|----------|----------|--|
| | A0 | /RD | /WR | D7 | D6 | D5 | D4 | D3 | D2 | D1 | D0 | |
| (1) Display ON/OFF | 0 | 1 | 0 | 1 | 0 | 1 | 0 | 1 | 1 | 1 | D | LCD display ON/OFF D=0: OFF; D=1:ON |
| (2) Display start line set | 0 | 1 | 0 | 0 | 1 | SA5 | SA4 | SA3 | SA2 | SA1 | SA0 | Set the display RAM display start line address (0-63) |
| (3) Page address set | 0 | 1 | 0 | 1 | 0 | 1 | 1 | PA3 | PA2 | PA1 | PA0 | Set the display RAM page address (0-8) |
| (4) Column address set upper bits | 0 | 1 | 0 | 0 | 0 | 0 | 1 | CA7 | CA6 | CA5 | CA4 | Set the upper 4 bits of the display RAM column address |
| Column address set lower bits | 0 | 1 | 0 | 0 | 0 | 0 | 0 | CA3 | CA2 | CA1 | CA0 | Set the lower 4 bits of the display RAM column address (0-131) |
| (5) Status read | 0 | 0 | 1 | BUSY | ADC | ON/OFF | RESET | 0 | 0 | 0 | 0 | Read the status data |
| (6) Display data write | 1 | 1 | 0 | D7 | D6 | D5 | D4 | D3 | D2 | D1 | D0 | Write data to the display RAM |
| (7) Display data read | 1 | 0 | 1 | D7 | D6 | D5 | D4 | D3 | D2 | D1 | D0 | Read data from the display RAM |
| (8) ADC select | 0 | 1 | 0 | 1 | 0 | 1 | 0 | 0 | 0 | 0 | ADC | Set the display RAM address SEG output correspondence ADC=0: normal, ADC=1: reverse |
| (9) Display normal/reverse | 0 | 1 | 0 | 1 | 0 | 1 | 0 | 0 | 1 | 1 | REV | Set LCD display normal/reverse REV=0: normal, REV=1: reverse |
| (10) Display all points ON/OFF | 0 | 1 | 0 | 1 | 0 | 1 | 0 | 0 | 1 | 0 | EON | Display all points EON=0: normal display EON=1: all points On |
| (11) LCD bias set | 0 | 1 | 0 | 1 | 0 | 1 | 0 | 0 | 0 | 1 | BIAS | Set LCD drive voltage bias ratio BIAS=0:1/9 bias, BIAS=1:1/7 bias |
| (12) Read/modify/write | 0 | 1 | 0 | 1 | 1 | 1 | 0 | 0 | 0 | 0 | 0 | Set read/modify/write mode |
| (13) End | 0 | 1 | 0 | 1 | 1 | 1 | 0 | 1 | 1 | 1 | 0 | Clear read/modify/write mode |
| (14) Reset | 0 | 1 | 0 | 1 | 1 | 1 | 0 | 0 | 0 | 1 | 0 | Internal reset |
| (15) Common output mode select | 0 | 1 | 0 | 1 | 1 | 0 | 0 | SHL | * | * | * | Select COM output scan direction SHL=0: normal direction SHL=1: reverse direction |
| (16) Power control set | 0 | 1 | 0 | 0 | 0 | 1 | 0 | 1 | VC | VR | VF | Select internal power supply operating mode |
| (17) V0 voltage regulator internal resistor ratio set | 0 | 1 | 0 | 0 | 0 | 1 | 0 | 0 | R2 | R1 | R0 | Select internal resistor ratio (Rb/Ra) mode (0-7) |
| (18) Electronic volume mode set | 0 | 1 | 0 | 1 | 0 | 0 | 0 | 0 | 0 | 0 | 1 | Set electronic volume mode |
| Electronic volume register set | 0 | 1 | 0 | 0 | 0 | EV5 | EV4 | EV3 | EV3 | EV1 | EV0 | Set electronic volume register (0-63) |
| (19) Static indicator ON/OFF | 0 | 1 | 0 | 1 | 0 | 1 | 0 | 1 | 1 | 0 | SM | SM=0: OFF, SM=1: ON Set static indicator flashing mode |
| Static indicator register set | 0 | 1 | 0 | 0 | 0 | 0 | 0 | 0 | 0 | S1 | S0 | Static Indicator function and command was canceled from ST7565P Ver 2.0 datasheet |
| (20) Booster ratio set | 0 0 | 1 1 | 0 0 | 1 0 | 1 0 | 1 0 | 1 0 | 1 0 | 0 0 | 0 BR1 | 0 BR0 | Select booster ratio |
| (21) Power saver | | | | | | | | | | | | Display OFF and display all points ON compound command |
| (22) NOP | 0 | 1 | 0 | 1 | 1 | 1 | 0 | 0 | 0 | 1 | 1 | Command for non-operation |
| (23) Test | 0 | 1 | 0 | 1 | 1 | 1 | 1 | 1 | 1 | * | * | Command for IC test. Do not use this command |

Note: Please refer to ST7565P datasheet for details.

“*”: Don't care

5. CONNECTION WITH 8051 FAMILY MPU

In order to reduce the transmission interference between MCU and lcm, it is suggested that 100pF capacitors should be added between GND and /CS1, A0, R/W, E signals.

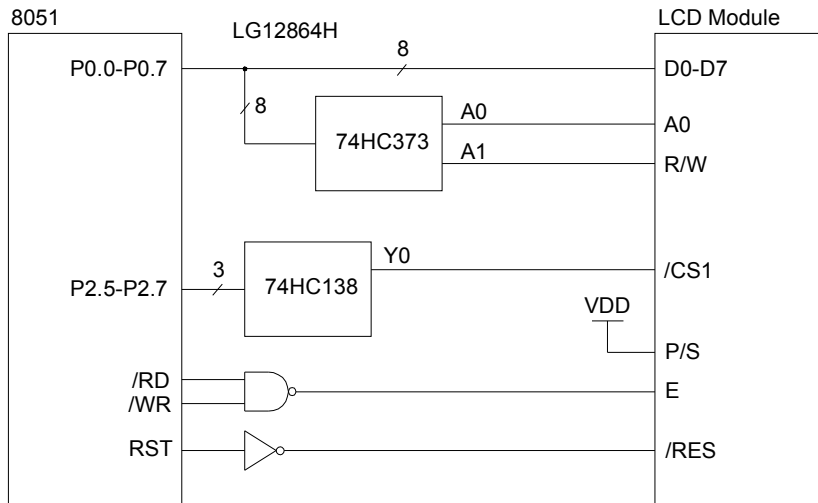

a. 8-bit parallel interface

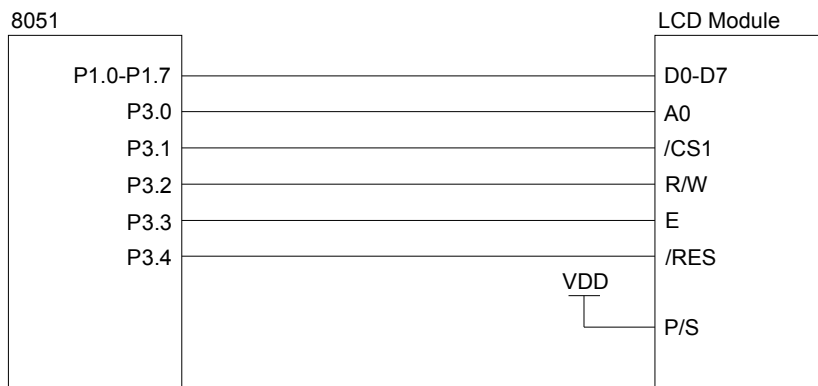

b. 8-bit parallel interface

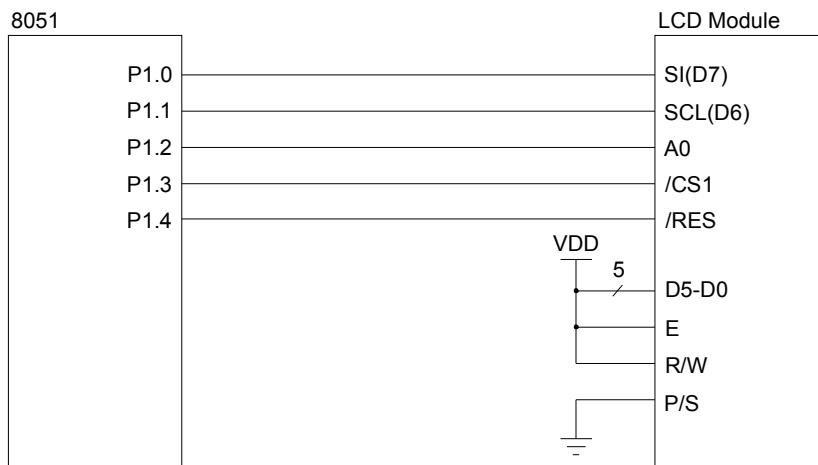

c. Serial interface

6. INITIALIZATION AND POWER OFF

6.1 Power on Initialization Sequence

| No. | Command | Description |
|-----|---|--|
| 1 | Power on | Power on |
| 2 | Reset | a. Keep /RES= "L" b. Wait for power stabilized (depends on system power) c. Release reset state: set /RES="H" d. Delay 10 us, then start the following initialization commands. |
| 3 | LCD bias set: A2H | Set LCD bias ratio: 1/9 bias |
| 4 | ADC select: A0H | Set LCD segment output pins normal direction |
| 5 | Common output mode select: C8H | Set LCD common output scan reverse direction |
| 6 | Booster ratio set: F8H, 00H (4x booster) | Select 4x booster |
| 7 | V0 voltage regulator Internal resistor ratio set: 25H | Set internal resistor ratio $(1+R_b/R_a)=5.5$ |
| 8 | Electronic volume register set: 81H, 28H | Set electronic volume register value=28H. "28H" is a reference value, modify this value to get the best display contrast. Because of the manufacturing dispersion of LCD modules, electronic volume register value may need be changed to match the driving voltage (V0) for different lot of LCD modules. |
| 9 | Power control set 2CH, 2EH, 2FH | a. Set booster circuit ON b. Set voltage regulator circuit ON c. Set voltage follower circuit ON |
| 10 | Display on: AFH | Set display ON |
| 11 | End of initialization | |

6.2 Power off Sequence

| No. | Command | Description |
|-----|----------------------|--|
| 1 | Optional status | Normal operation |
| 2 | Power save: AEH, A5H | a. Set display OFF b. Set display all points ON |
| 3 | Reset | a. Set /RES= "L" b. Delay 50ms, then power off |
| 4 | Power off | |

7. ELECTRO-OPTICAL CHARACTERISTICS (Ta=25°C)

| Item | Symbol | Condition | Min. | Typ. | Max. | Unit | Note |
|----------------|-----------------|------------------------------------|------|------|------|------|--------------|
| View Angle | $\Phi 2-\Phi 1$ | $Cr \geq 2, \theta = 0^\circ$ | - | 70 | - | Deg | Note1, Note2 |
| Contrast Ratio | Cr | $\Phi = 0^\circ, \theta = 0^\circ$ | 3 | - | - | - | Note3 |
| Response Time | tr (rise) | $\Phi = 0^\circ, \theta = 0^\circ$ | - | 200 | - | ms | Note4 |
| | tf (fall) | $\Phi = 0^\circ, \theta = 0^\circ$ | - | 250 | - | ms | |

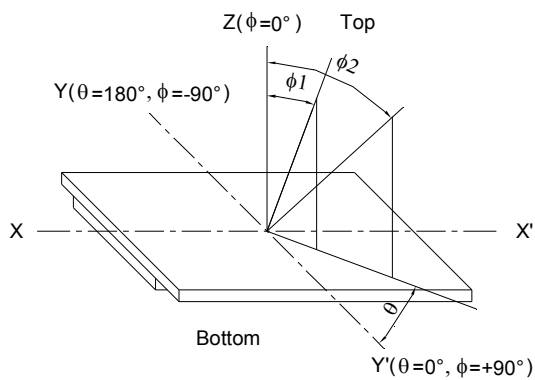

Note1: Definition of viewing angle ϕ, θ

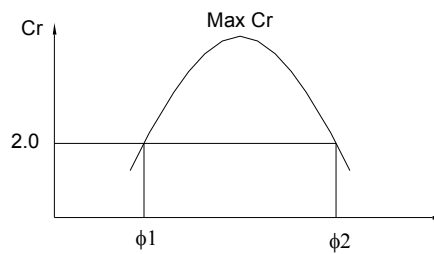

Note2: Definition of viewing angle range $\phi 1, \phi 2$

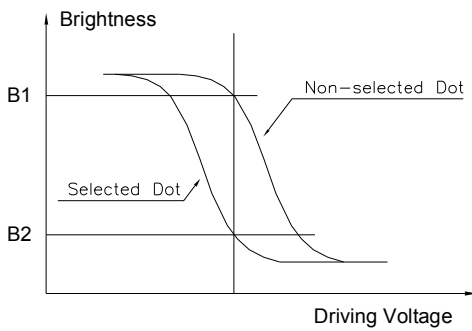

$$\text{Contrast Ratio} = \frac{\text{Brightness of non-selected dot (B1)}}{\text{Brightness of selected dot (B2)}}$$

Note3: Definition of contrast ratio (positive type)

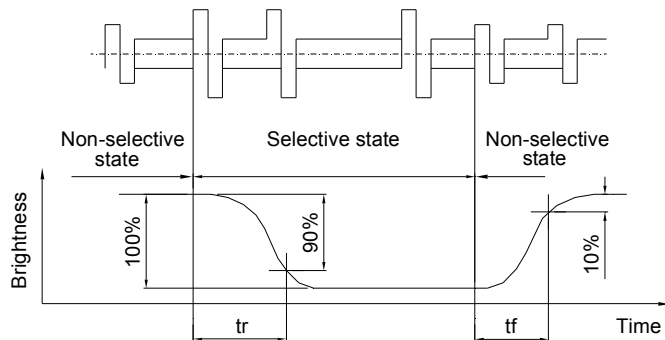

Note3: Definition of response time

8. DIMENSIONAL OUTLINE

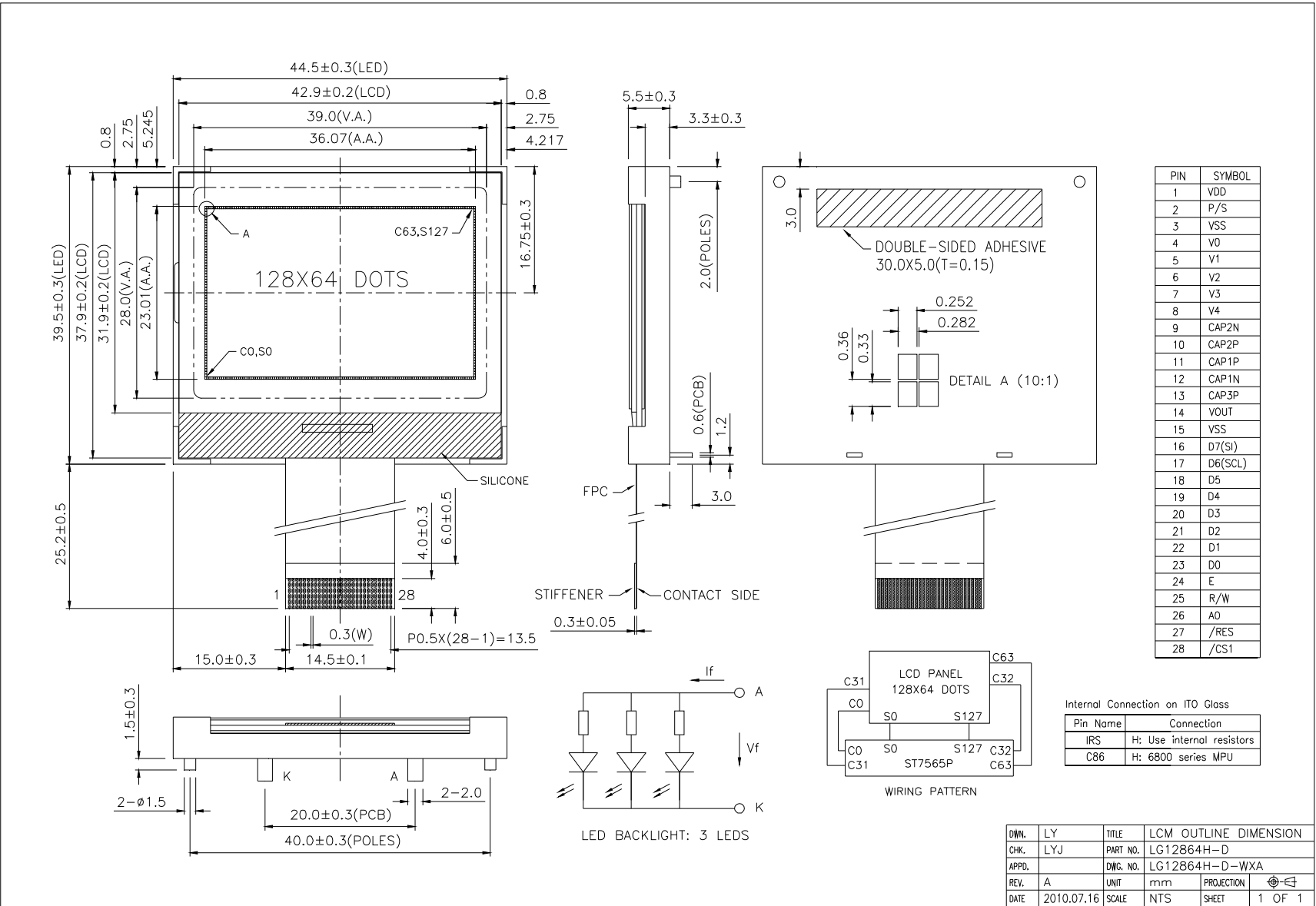

9. LCD MODULE NUMBERING SYSTEM

L G 128 64 H - F F D W H 6 V - XXXX
 (1) (2) (3) (4) (5) (6) (7) (8) (9) (10) (11) (12) (13)

(1) Brand

(2) Module type

C - Character module

G - Graphic module

(3) Display format

Character module : Number of characters per line, two digits XX

Graphic module : Number of columns, three digits XXX

(4) Display format

Character module : Number of lines, one digit X

Graphic module : Number of rows, two or three digits XX or XXX

(5) Development number : One or two digits X or XX

(6) LCD mode

T - TN Positive, Gray

N - TN Negative, Blue

S - STN Positive, Yellow green

G - STN Positive, Gray

B - STN Negative, Blue

F - FSTN Positive, White

K - FSTN Negative, Black

L - FSTN Negative, Blue

Q - FFSTN Negative, Black

(7) Polarizer mode

R - Reflective

F - Transflective

M - Transmissive

(8) Backlight type

N - Without backlight

L - Array LED

D - Edge light LED

E - EL

C - CCFL

(9) Backlight color

Y - Yellow green

B - Blue

W - White

G - Green

A - Amber

R - Red

M - Multi color

Nil - Without backlight

(10) Operating temperature range

S - Standard temperature (0 to +50 °C)

H - Extended temperature (-20 to +70 °C)

(11) Viewing direction

3 - 3:00

6 - 6:00

9 - 9:00

U - 12:00

(12) DC-DC Converter

N or Nil - Without DC-DC converter

V - Built in DC-DC converter

(13) Version code

Nil or 0 to ZZZZZ - Version code

10. PRECAUTIONS FOR USE OF LCD MODULE

10.1 Handling Precautions

- 1) The display panel is made of glass. Do not subject it to a mechanical shock by dropping it from a high place, etc.
- 2) If the display panel is damaged and the liquid crystal substance inside it leaks out, be sure not to get any in your mouth. If the substance comes into contact with your skin or clothes, promptly wash it off using soap and water.
- 3) Do not apply excessive force on the surface of display or the adjoining areas of LCD module since this may cause the color tone to vary.
- 4) The polarizer covering the display surface of the LCD module is soft and easily scratched. Handle this polarizer carefully.
- 5) If the display surface of LCD module becomes contaminated, blow on the surface and gently wipe it with a soft dry cloth. If it is heavily contaminated, moisten cloth with one of the following solvents.
 - Isopropyl alcohol
 - Ethyl alcoholSolvents other than those mentioned above may damage the polarizer. Especially, do not use the following:
 - Water
 - Ketone
 - Aromatic Solvents
- 6) When mounting the LCD module make sure that it is free of twisting, warping, and distortion. Distortion has great influence upon display quality. Also keep the stiffness enough regarding the outer case.
- 7) Be sure to avoid any solvent such as flux for soldering never stick to Heat-Seal. Such solvent on Heat-Seal may cause connection problem of heat-Seal and TAB.
- 8) Do not forcibly pull or bend the TAB I/O terminals.
- 9) Do not attempt to disassemble or process the LCD module.
- 10) NC terminal should be open. Do not connect anything.
- 11) If the logic circuit power is off, do not apply the input signals.
- 12) To prevent destruction of the elements by static electricity, be careful to maintain an optimum work environment.
 - Be sure to ground the body when handling the LCD module.
 - Tools required for assembly, such as soldering irons, must be properly grounded.
 - To reduce the amount of static electricity generated, do not conduct assembly and other work under dry conditions.
 - The LCD module is coated with a film to protect the display surface. Exercise care when peeling off this protective film since static electricity may be generated.

10.2 Storage Precautions

- 1) When storing the LCD module, avoid exposure to direct sunlight or to the light of fluorescent lamps and high temperature/high humidity. Whenever possible, the LCD module should be stored in the same conditions in which they were shipped from our company.

- 2) Exercise care to minimize corrosion of the electrodes. Corrosion of the electrodes is accelerated by water droplets or a current flow in a high humidity environment.

10.3 Design Precautions

- 1) The absolute maximum ratings represent the rated value beyond which LCD module can not exceed. When the LCD modules are used in excess of this rated value, their operating characteristics may be adversely affected.
- 2) To prevent the occurrence of erroneous operation caused by noise, attention must be paid to satisfy VIL, VIH specification values, including taking the precaution of using signal cables that are short.
- 3) The liquid crystal display exhibits temperature dependency characteristics. Since recognition of the display becomes difficult when the LCD is used outside its designated operating temperature range, be sure to use the LCD within this range. Also, keep in mind that the LCD driving voltage levels necessary for clear displays will vary according to temperature.
- 4) Sufficiently notice the mutual noise interference occurred by peripheral devices.
- 5) To cope with EMI, take measures basically on outputting side.
- 6) If DC is impressed on the liquid crystal display panel, display definition is rapidly deteriorated by the electrochemical reaction that occurs inside the liquid crystal display panel. To eliminate the opportunity of DC impressing, be sure to maintain the AC characteristics of the input signals sent to the LCD Module.

10.4 Others

- 1) Liquid crystals solidify under low temperatures (below the storage temperature range) leading to defective orientation or the generation of air bubbles (black or white). Air bubbles may also be generated if the LCD module is subjected to a strong shock at a low temperature.
- 2) If the LCD modules have been operating for a long time showing the same display patterns, the display patterns may remain on the screen as ghost images and a slight contrast irregularity may also appear. A normal operating status can be regained by suspending use for some time. It should be noted that this phenomenon does not adversely affect performance reliability.
- 3) To minimize the performance degradation of the LCD modules resulting from destruction caused by static electricity, etc., exercise care to avoid touching the following sections when handling the module:
 - Terminal electrode sections.
 - Part of pattern wiring on TAB, etc.